

1. 尺寸: Dimensions; Unit: mm

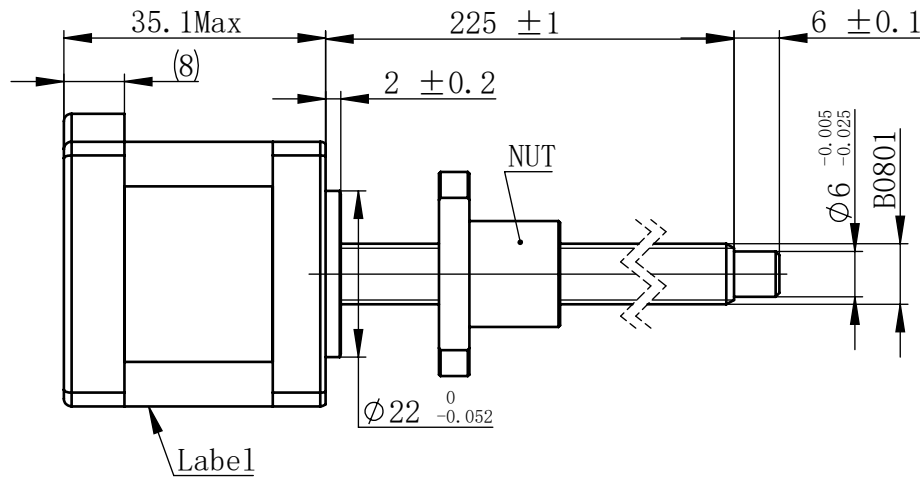

2. 接线图 Wiring Diagram

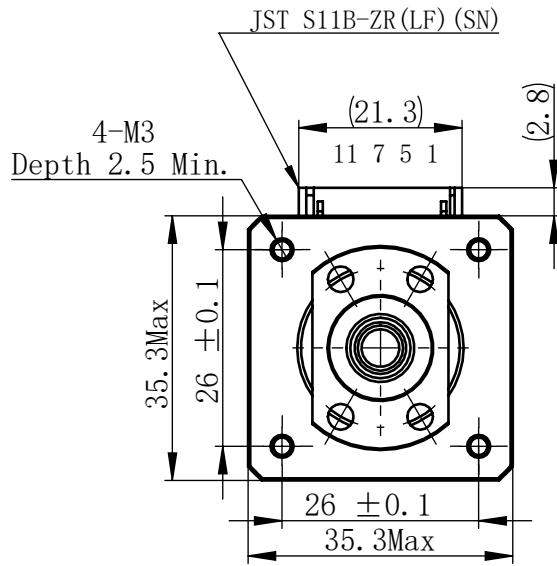
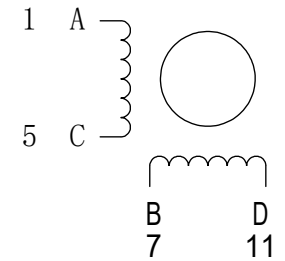

3. 励磁顺序 vs. 旋转方向 Exciting Sequence vs. Direction of Rotation

STEP	A	B	C	D	CCW
1	+	+	-	-	↑
2	-	+	+	-	
3	-	-	+	+	
4	+	-	-	+	

↓ CW

从安装面看为顺时针方向
Clockwise view from mounting side

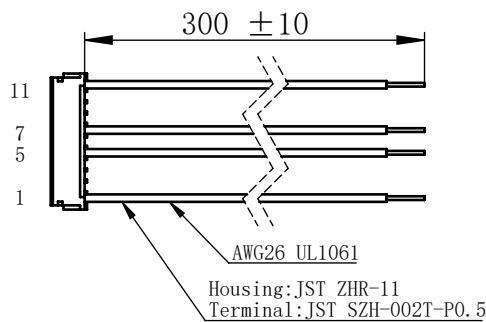

连接器针位 vs. 引线颜色
Pin No. vs. Lead Wire Colour

Pin No.	颜色 Colour
1	黑 BLK
5	绿 GRN
7	红 RED
11	蓝 BLU

Nut

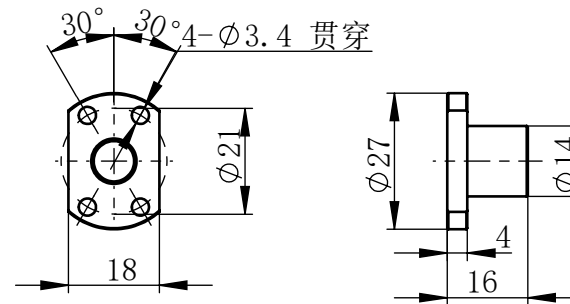

4. 电机标签 Motor label

MOONS' BALL SCREW MOTOR
BE143S-B0801-225-A1P-S-150
XXXXXXXXXX

批次号

技术要求:

- 未注尺寸公差参照GB/T 1804-M;
- 丝杠和螺母配对使用, 运行流畅不卡顿, 无异音;
- 丝杠表面无擦伤, 锈斑等不良;
- 螺母安装方向与图中保持一致。

未标注线性尺寸和公差 Tolerance for linear and dimensions without individual tolerance indications GB/T 1804-M eqv ISO 2768-1:M		设计 Design	母飞翔	2024/12/29	First Angle Method	MOONS' moving in better ways	上海市闵行区 鸣嘉路168号 (021)52634688	
未标注形状与位置尺寸公差 Geometrical tolerance for features without individual tolerance indications GB/T 1184-K eqv ISO 2768-2:K		校核 Check					比例 Scale	零件名 Part Name
I. 请避免螺母脱离丝杠 Keep nut on screw. II. 非专业人士请勿拆解电机 Avoid disassembly without qualification.		工艺 Process			材料 Material	总图	2:3	型号 Model NO. BE143S-B0801-225-A1P-S-150
		标准化 Standard					Page 1 of 2	版本 Version A0
批准 Approve								

版本变更

版本	变更说明	签名	日期
A0	初始版本	母飞翔	2024/12/26

