

物料号  
Material NO.

Unit: mm

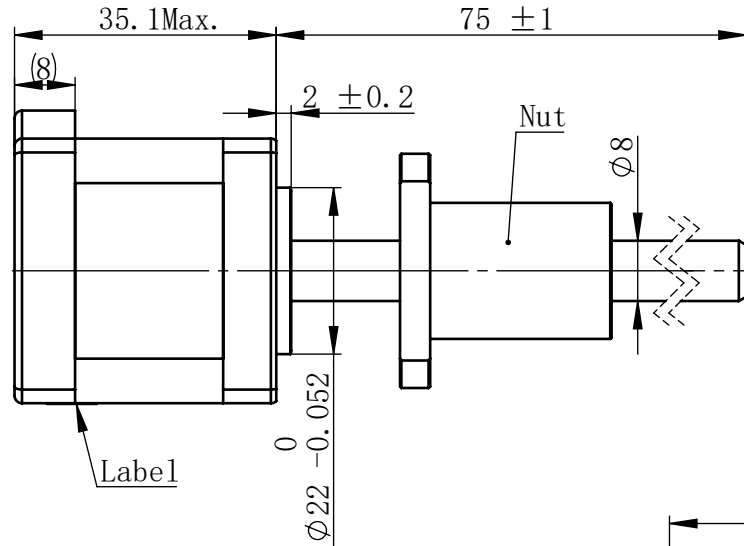

接线图  
Wiring Diagram

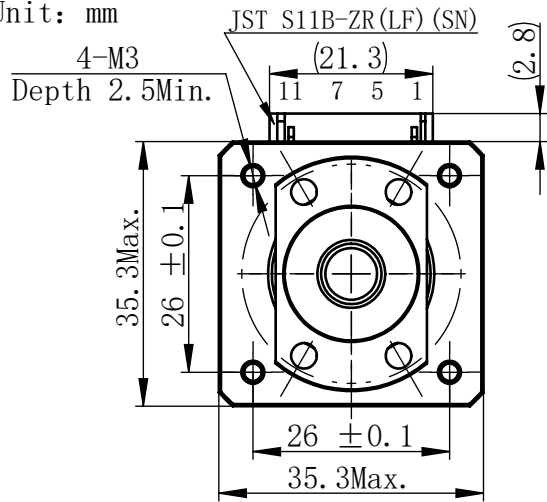
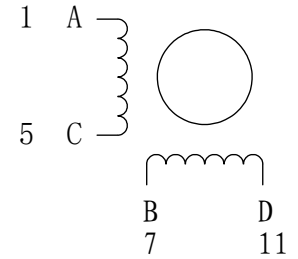

励磁顺序 vs. 旋转方向  
Exciting Sequence vs.  
Direction of Rotation

STEP	A	B	C	D
1	+	+	-	-
2	-	+	+	-
3	-	-	+	+
4	+	-	-	+

CW  
CCW

草图阶段，图纸仅用于技术交流。  
This draft drawing is for communication purpose only.

规格  
Specifications

1	相数 Number Of Phase	2
2	步长 Linear Travel/Step	0.025 mm (1.8°)
3	额定电压 Rated Voltage	2.4 V DC
4	额定电流 Rated Current	1.5 Amp
5	额定推力 Rated Thrust	54 N(@300rpm, rated current)
6	相电阻 Phase Resistance	1.61 ohm ± 10% (20°C)
7	相电感 Phase Inductance	2.5 mH ± 20% (1kHz 1V rms)
8	转子惯量 Rotor Inertia	20 gcm <sup>2</sup>
9	重量 Weight	0.21 Kg
10	绝缘等级 Insulation Class	B(130°C)
11	丝杠直径 Screw Diameter	8 mm
12	丝杠导程 Lead	5 mm

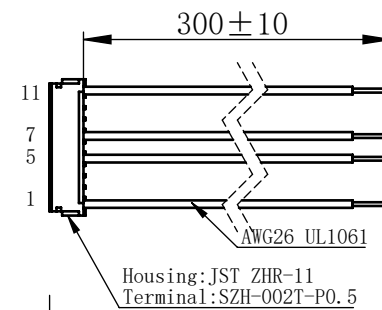
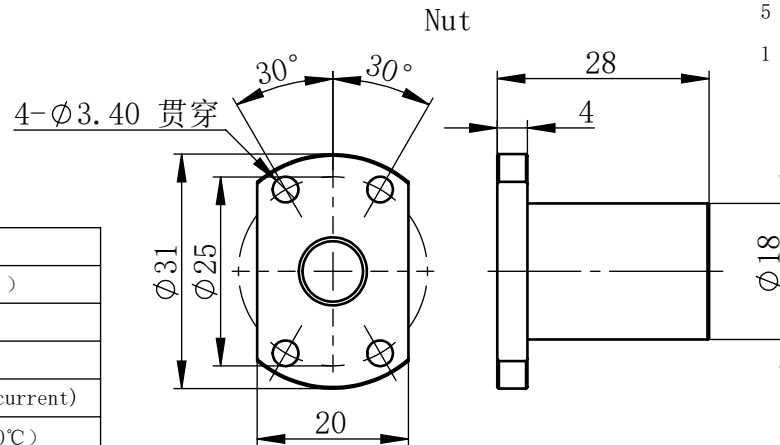

连接器针位 vs. 引线颜色  
Pin No. vs. Lead Wire Colour

Pin No.	颜色 Colour
1	黑 BLK
5	绿 GRN
7	红 RED
11	蓝 BLU

从安装面看为顺时针方向  
Clockwise view from  
mounting side

电机标签  
Motor label

MOONS' BALL SCREW MOTOR  
BE143S-B0805-75-FF1-0-150  
XXXXXXXX

批次号

版本变更

版本	变更说明	签名	日期

未标注线性尺寸和公差  
Tolerance for linear and dimensions  
without individual tolerance indications  
GB/T 1804-M eqv ISO 2768-1:M

未标注形状与位置尺寸公差  
Geometrical tolerance for features  
without individual tolerance indications  
GB/T 1184-K eqv ISO 2768-2:K



- 请避免螺母脱离丝杠  
Keep nut on screw.
- 非专业人士请勿拆解电机  
Avoid disassembly without  
qualification.

设计 Design	张杰	2023/11/27
校核 Check		
工艺 Process		
标准化 Standard		
批准 Approve		

第一角画法  
First Angle Method

材料 Material

张杰

Page 1 of 1

版本 Version

比例 Scale

1:1

零件名 Part Name

直线步进电机

型号 Model NO.

BE143S-B0805-75-FF1-0-150

物料号 Material NO.

**MOONS'**  
moving in better ways

上海市闵行区  
鸣嘉路168号  
(021)52634688