

1. 尺寸: Dimensions; Unit: mm

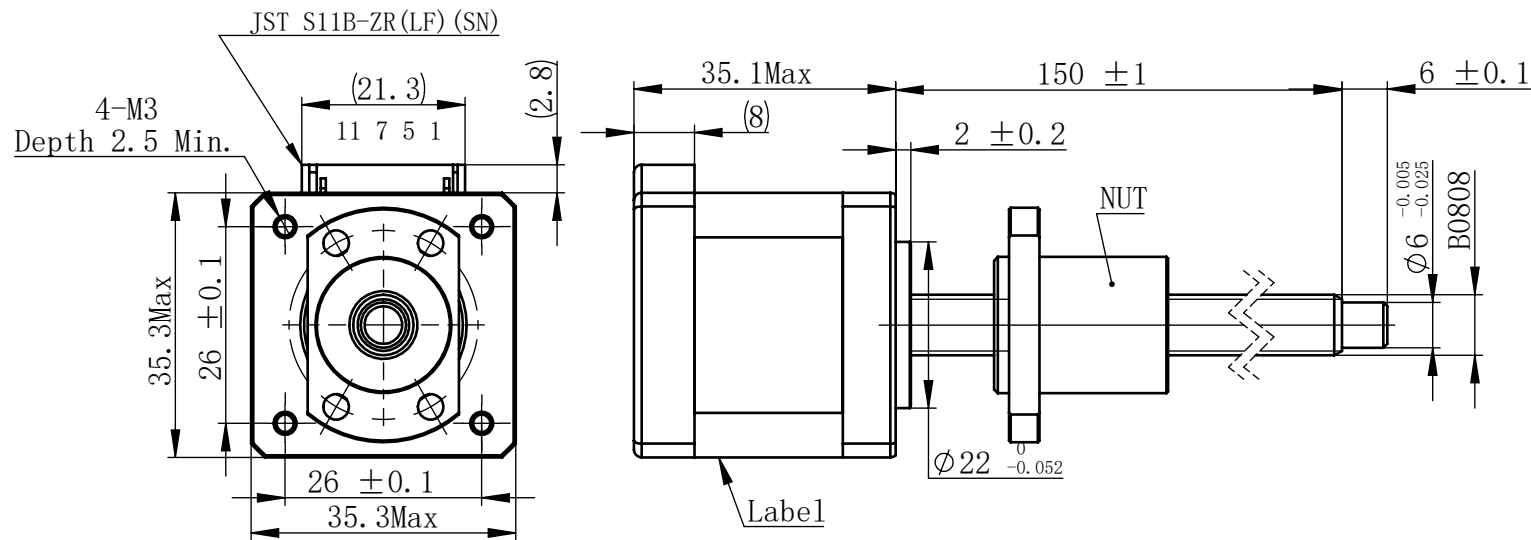

2. 接线图 Wiring Diagram

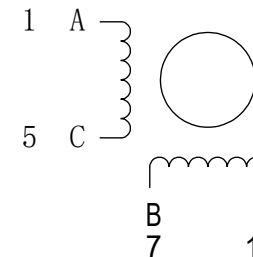

3. 励磁顺序 vs. 旋转方向 Exciting Sequence vs. Direction of Rotation

STEP	A	B	C	D	CCW
1	+	+	-	-	↑
2	-	+	+	-	
3	-	-	+	+	
4	+	-	-	+	

↓ CW

从安装面看为顺时针方向
Clockwise view from mounting side

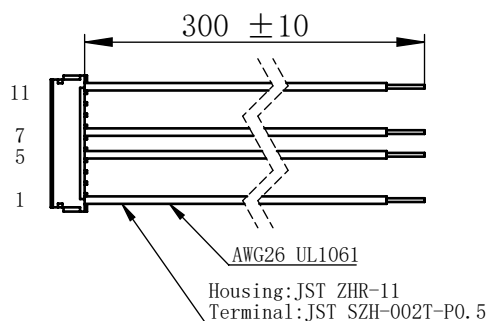

连接器针位 vs. 引线颜色
Pin No. vs. Lead Wire Colour

Pin No.	颜色 Colour
1	黑 BLK
5	绿 GRN
7	红 RED
11	蓝 BLU

Nut

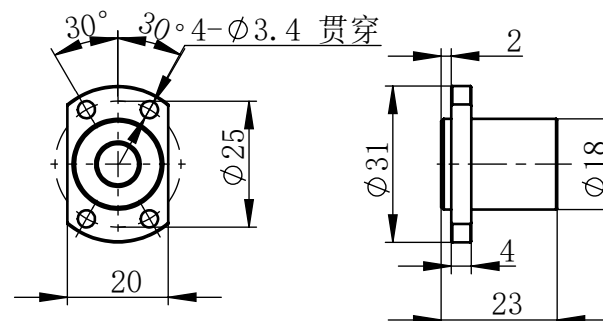

4. 电机标签 Motor label

MOONS' BALL SCREW MOTOR
BE143S-B0808-150-B1P-S-150
XXXXXXXXXX

批次号

技术要求:

- 未注尺寸公差参照GB/T 1804-M;
- 丝杠和螺母配对使用, 运行流畅不卡顿, 无异音;
- 丝杠表面无擦伤, 锈斑等不良;
- 螺母安装方向与图中保持一致。

未标注线性尺寸和公差 Tolerance for linear and dimensions without individual tolerance indications GB/T 1804-M eqv ISO 2768-1:M		设计 Design	母飞翔	2024/12/27	第一角法 First Angle Method	MOONS' moving in better ways	上海市闵行区 鸣嘉路168号 (021)52634688	
未标注形状与位置尺寸公差 Geometrical tolerance for features without individual tolerance indications GB/T 1184-K eqv ISO 2768-2:K		校核 Check					比例 Scale	零件名 Part Name
I. 请避免螺母脱离丝杠 Keep nut on screw.		工艺 Process			材料 Material	总图	2:3	型号 Model NO. BE143S-B0808-150-B1P-S-150
II. 非专业人士请勿拆解电机 Avoid disassembly without qualification.		标准化 Standard					Page 1 of 2	版本 Version A0

版本变更

版本	变更说明	签名	日期
A0	初始版本	母飞翔	2024/12/26

产品规格书 Specification

5. 参数规格: Technique Parameter:

7. 注意事项: Note:

参数表 Parameter List	
相数 Number Of Phase	2
步长 Linear Travel/Step	0.04 mm (1.8°)
额定电压 Rated Voltage	2.4 V DC
额定电流 Rated Current	1.5 Amp
额定推力 Rated Thrust	25 N(@300rpm, rated current)
相电阻 Phase Resistance	1.61 ohm±15% (20°C)
相电感 Phase Inductance	2.5 mH±20% (1kHz 1V rms)
转子惯量 Rotor Inertia	20 gcm ²
重量 Weight	0.21 Kg
绝缘等级 Insulation Class	B(130°C)
丝杠直径 Screw Diameter	8 mm
丝杠导程 Lead	8 mm
旋向 Direction of thread	右旋RH
精度等级 Accuracy level	C7
轴向间隙 Axial clearance	±0.02mm

1. 丝杠不得承受径向负载, 不能夹装或者硬物敲击;

The screw cannot bear radial load, and it cannot be subjected to clamping or hard object striking.

2. 丝杠和螺母配对使用, 请勿自行拆卸, 如有需求请与厂商联系;

Screw and nut should be paired in use, Please do not disassemble it yourself. If necessary, please contact the manufacturer;

3. 丝杠已涂覆专用油脂, 如有加脂需求, 请与厂商联系;

The screw have been coated with special lubricant. If you need to add lubricant, please contact the manufacturer.

4. 使用时避免油污、切削液、过多粉尘、腐蚀性或可燃性气体和液体等特殊环境;

Avoid special environments. Such as: oil pollution、cutting fluid、excessive dust、corrosive,

or flammable gases and liquids during operating.

5. 工作温度: -20~60°C (不结冰, 不结露),

储存温度: -20~80°C (不结冰, 不结露)

如有特殊需求, 请与厂商联系;

Operating temperature: -20~60°C (no freezing, no condensation),

Storage temperature: -20~80°C (no freezing, no condensation)

Please contact the manufacturer if you have special requirements.

6. 建议保养时间每三个月/半年一次, 具体时间请根据工况调整。

Suggested maintenance time: every 3 months/6 months, specific time should be adjusted

according to the working conditions.

6. 特殊特性: Special Characteristics:

1. 无

版本变更				设计 Design	母飞翔	2024/12/27	第一角法 First Angle Method	材料 Material	总图	比例 Scale	零件名 Part Name	直线步进电机
版本	变更说明	签名	日期									
A0	初始版本	母飞翔	2024/12/26	未标注线性尺寸和公差 Tolerance for linear and dimensions without individual tolerance indications GB/T 1804-M eqv ISO 2768-1:M		未标注形状与位置尺寸公差 Geometrical tolerance for features without individual tolerance indications GB/T 1184-K eqv ISO 2768-2:K		I. 请避免螺母脱离丝杠 Keep nut on screw.		2:3	型号 Model NO.	BE143S-B0808-150-B1P-S-150
				II. 非专业人士请勿拆解电机 Avoide disassembly without qualification.		批准 Approve	Page 2 of 2	版本 Version	A0	物料号 Material NO.	4611230001913	