

物料号 Material NO. 461123000260

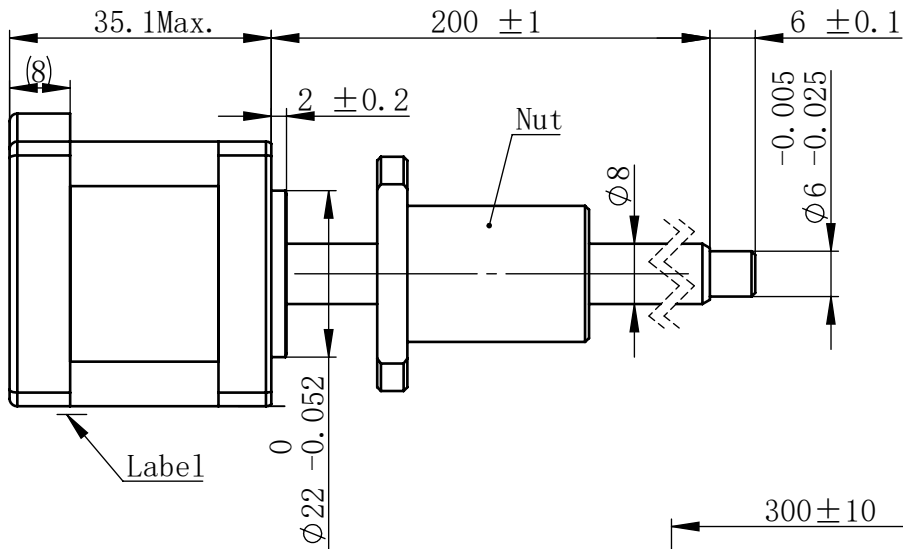

接线图  
Wiring Diagram

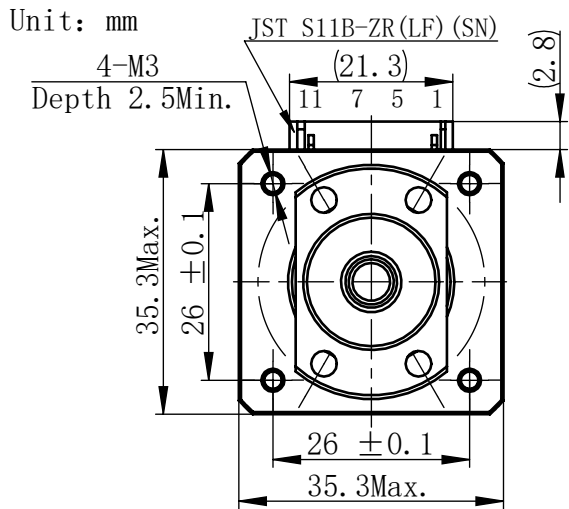
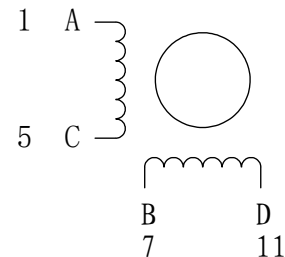

励磁顺序 vs. 旋转方向  
Exciting Sequence vs. Direction of Rotation

STEP	A	B	C	D	
1	+	+	-	-	↑ CCW ↓ CW
2	-	+	+	-	
3	-	-	+	+	
4	+	-	-	+	

从安装面看为顺时针方向  
Clockwise view from mounting side

电机标签  
Motor label

MOONS' BALL SCREW MOTOR  
BE143S-B0808-200-FF1-S-150  
XXXXXXX

批次号

规格  
Specifications

1	相数 Number Of Phase	2
2	步长 Linear Travel/Step	0.04 mm (1.8°)
3	额定电压 Rated Voltage	2.4 V DC
4	额定电流 Rated Current	1.5 Amp
5	额定推力 Rated Thrust	34 N(@300rpm, rated current)
6	相电阻 Phase Resistance	1.61 ohm ± 10% (20°C)
7	相电感 Phase Inductance	2.5 mH ± 20% (1kHz 1V rms)
8	转子惯量 Rotor Inertia	20 gcm <sup>2</sup>
9	重量 Weight	0.21 Kg
10	绝缘等级 Insulation Class	B(130°C)
11	丝杠直径 Screw Diameter	8 mm
12	丝杠导程 Lead	8 mm

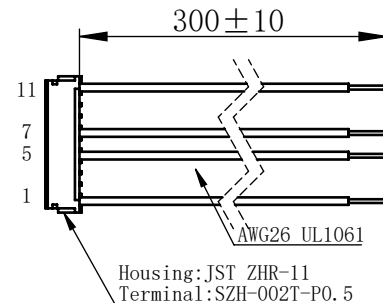
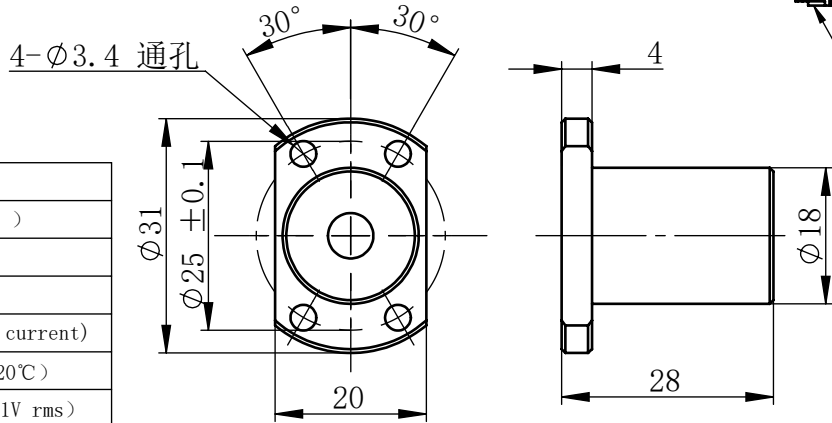

连接器针位 vs. 引线颜色  
Pin No. vs. Lead Wire Colour

Pin No.	颜色 Colour
1	黑 BLK
5	绿 GRN
7	红 RED
11	蓝 BLU

未标注线性尺寸和公差  
Tolerance for linear and dimensions without individual tolerance indications  
GB/T 1804-M eqv ISO 2768-1:M

未标注形状与位置尺寸公差  
Geometrical tolerance for features without individual tolerance indications  
GB/T 1184-K eqv ISO 2768-2:K

设计 Design	母飞翔	2021/10/10
校核 Check		
工艺 Process		
标准化 Standard		
批准 Approve		

第一角画法  
First Angle Method



上海市闵行区  
鸣嘉路168号  
(021)52634688

版本变更			
版本	变更说明	签名	日期

I. 请避免螺母脱离丝杠  
Keep nut on screw.

II. 非专业人士请勿拆解电机  
Avoid disassembly without qualification.

材料 Material	总图	比例 Scale	零件名 Part Name	直线步进电机
Page 1 of 1	版本 Version	A0	型号 Model NO.	BE143S-B0808-200-FF1-S-150
			物料号 Material NO.	461123000260