

Material NO. 4611230000262

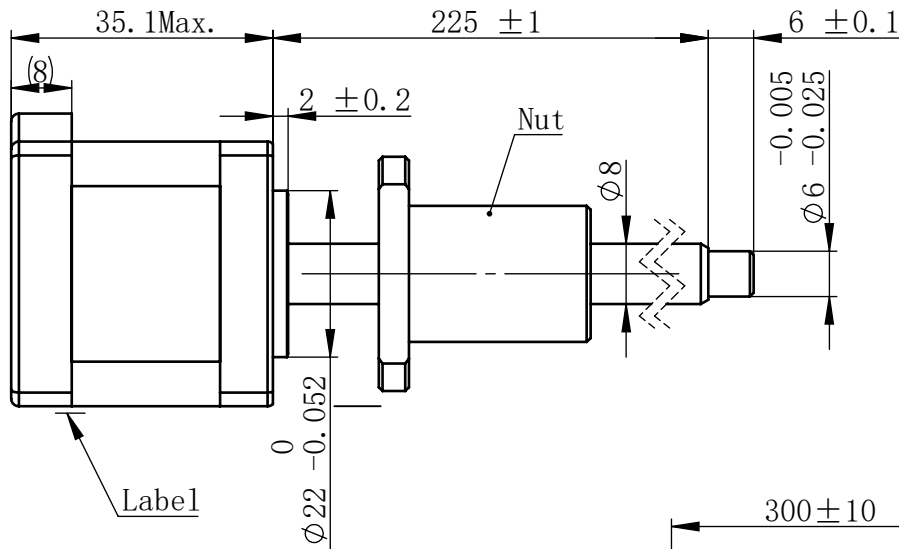

接线图  
Wiring Diagram

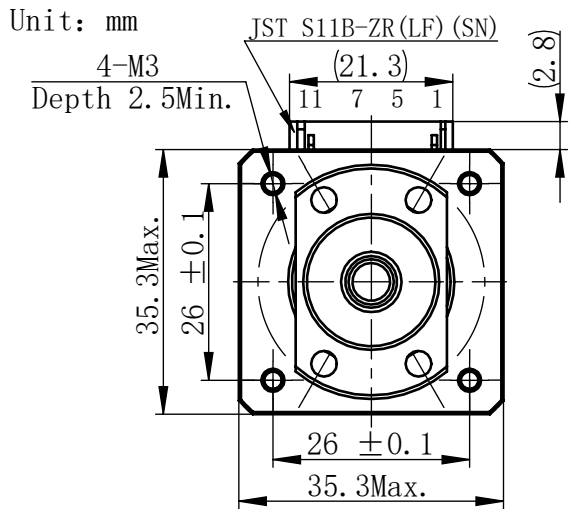
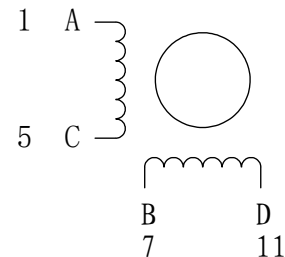

励磁顺序 vs. 旋转方向  
Exciting Sequence vs. Direction of Rotation

STEP	A	B	C	D	
1	+	+	-	-	↑ CCW ↓ CW
2	-	+	+	-	
3	-	-	+	+	
4	+	-	-	+	

规格  
Specifications

1	相数 Number Of Phase	2
2	步长 Linear Travel/Step	0.04 mm (1.8°)
3	额定电压 Rated Voltage	2.4 V DC
4	额定电流 Rated Current	1.5 Amp
5	额定推力 Rated Thrust	34 N(@300rpm, rated current)
6	相电阻 Phase Resistance	1.61 ohm ± 10% (20°C)
7	相电感 Phase Inductance	2.5 mH ± 20% (1kHz 1V rms)
8	转子惯量 Rotor Inertia	20 gcm <sup>2</sup>
9	重量 Weight	0.21 Kg
10	绝缘等级 Insulation Class	B(130°C)
11	丝杠直径 Screw Diameter	8 mm
12	丝杠导程 Lead	8 mm

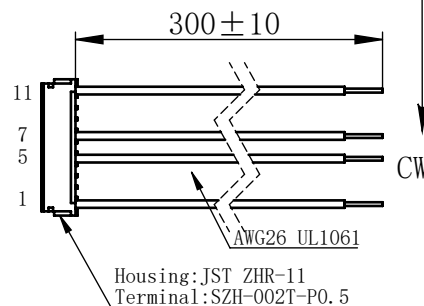
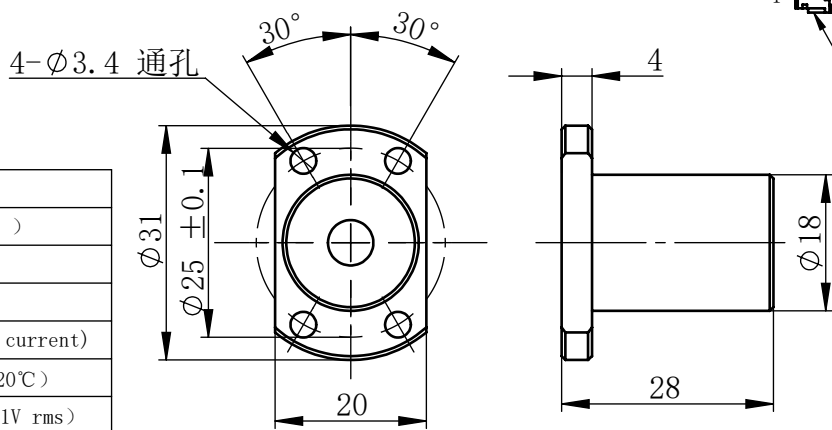

连接器针位 vs. 引线颜色  
Pin No. vs. Lead Wire Colour

Pin No.	颜色 Colour
1	黑 BLK
5	绿 GRN
7	红 RED
11	蓝 BLU

从安装面看为顺时针方向  
Clockwise view from mounting side

电机标签  
Motor label

MOONS' BALL SCREW MOTOR  
BE143S-B0808-225-FF1-S-150  
XXXXXXX

批次号

版本变更

版本	变更说明	签名	日期

未标注线性尺寸和公差  
Tolerance for linear and dimensions without individual tolerance indications GB/T 1804-M eqv ISO 2768-1:M

未标注形状与位置尺寸公差  
Geometrical tolerance for features without individual tolerance indications GB/T 1184-K eqv ISO 2768-2:K

I. 请避免螺母脱离丝杠  
Keep nut on screw.

II. 非专业人士请勿拆解电机  
Avoid disassembly without qualification.

设计 Design	母飞翔	2023/11/29
校核 Check		
工艺 Process		
标准化 Standard		
批准 Approve		

材料 Material

总图

Page 1 of 1

版本 Version A0

**MOONS'** moving in better ways

上海市闵行区 鸣嘉路168号 (021)52634688

比例 Scale	零件名 Part Name
1:1	直线步进电机
	型号 Model NO. BE143S-B0808-225-FF1-S-150
	物料号 Material NO. 4611230000262